



## Model WHARSS5

How to install, operate  
and maintain your  
In-Line Refrigerator  
Water Filtration System

Do not return unit to store

If you have any questions or concerns when installing, operating or maintaining your water filtration system, call our toll free number:

**1-866-986-3223**

Monday- Friday, 8 AM - 7 PM EST or visit  
**[whirlpoolwatertreatment.com](http://whirlpoolwatertreatment.com)**

When you call, please be prepared to provide the model number and date code of your product, found on the filter head.

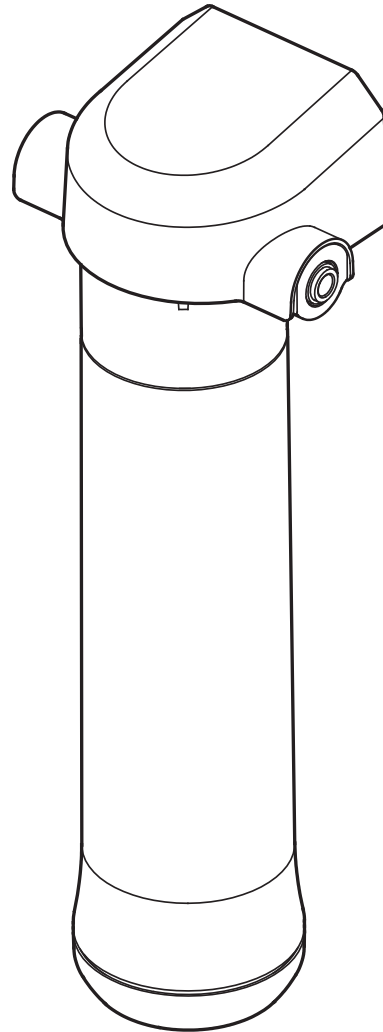

System tested and certified by NSF International against NSF/ANSI Standards 42 & 53. See performance data on page 3 for details.



Manufactured and warranted by  
Ecodyne Water Systems  
1890 Woodlane Drive  
Woodbury, MN 55125

201-8402812 (Rev. 02 5/4/15)

**Installation and Operation Manual**

# TABLE OF CONTENTS

	<u>Page</u>
Specifications & Performance Claims . . . . .	3
Before You Start . . . . .	4
Dimensions . . . . .	4
Parts & Tools . . . . .	5
Pre-Installation Inspection . . . . .	5
Installation Location . . . . .	5
Installation Instructions . . . . .	5
Make Tubing Connections . . . . .	6
Turn On Water, Check for Leaks and Rinse Carbon Fines . . . . .	6
Filter Cartridges . . . . .	7
Filter Cartridge Life . . . . .	7
Filter Cartridge Replacement . . . . .	7
Troubleshooting the System . . . . .	8
Exploded View & Parts List . . . . .	8

## WARRANTY

### ONE YEAR LIMITED WARRANTY ON IN-LINE REFRIGERATOR WATER FILTRATION SYSTEM (except filter cartridges)

**Warrantor: Ecodyne Water Systems, 1890 Woodlane Drive, Woodbury, MN 55125**

Warrantor guarantees, to the original owner, that the Water Filtration System, when installed and maintained in accordance with the instructions, will be free from defects in materials and workmanship for a period of one (1) year from the date of purchase. If, within the first year, a part proves, after inspection, to be defective, Warrantor will, at its sole option, either replace or repair the part without charge except normal shipping and installation charges. Labor to maintain the equipment is not part of the warranty. Filters, which are expendable, are not covered by the warranty.

TO OBTAIN WARRANTY PARTS, SIMPLY CALL 1-866-986-3223, Monday - Friday, 8 am - 7 pm EST, for assistance. This warranty applies only while this product is in use in the United States or Canada.

#### General Provisions

The above warranties are effective provided the Water Filtration System is operated at water pressures not exceeding 100 psi, and at water temperatures not exceeding 100°F; provided further that the Water Filtration System is not subject to abuse, misuse, alteration, neglect, freezing, accident or negligence; and provided further that the Water Filtration System is not damaged as the result of any unusual force of nature such as, but not limited to, flood, hurricane, tornado or earthquake.

Warrantor is excused if failure to perform its warranty obligations is the result of strikes, government regulation, materials shortages, or other circumstances beyond its control.

**\*THERE ARE NO WARRANTIES ON THE WATER FILTRATION SYSTEM BEYOND THOSE SPECIFICALLY DESCRIBED ABOVE. ALL IMPLIED WARRANTIES, INCLUDING ANY IMPLIED WARRANTY OF MERCHANTABILITY OR OF FITNESS FOR A PARTICULAR PURPOSE, ARE DISCLAIMED TO THE EXTENT THEY MIGHT EXTEND BEYOND THE ABOVE PERIODS. THE SOLE OBLIGATION OF WARRANTOR UNDER THESE WARRANTIES IS TO REPLACE OR REPAIR THE COMPONENT OR PART WHICH PROVES TO BE DEFECTIVE WITHIN THE SPECIFIED TIME PERIOD, AND WARRANTOR IS NOT LIABLE FOR CONSEQUENTIAL OR INCIDENTAL DAMAGES. NO WARRANTOR DEALER, AGENT, REPRESENTATIVE, OR OTHER PERSON IS AUTHORIZED TO EXTEND OR EXPAND THE WARRANTIES EXPRESSLY DESCRIBED ABOVE.**

Some states do not allow limitations on how long an implied warranty lasts or exclusions or limitations of incidental or consequential damage, so the limitations and exclusions in this warranty may not apply to you. This warranty gives you specific legal rights, and you may have other rights which vary from state to state. This warranty applies to consumer-owned installations only.

®/TM ©2015 Whirlpool. All rights reserved.

Manufactured under license by Ecodyne Water Systems, Woodbury, Minnesota.

# Specifications & Performance Claims

SPECIFICATIONS	
Supply Water Pressure Min. - Max.	30 - 100 psi (207 - 689 kPa)
Supply Water Temperature Min. - Max.	40 - 100 °F (4 - 38 °C)
Rated Service Flow	0.5 gallons per minute (1.89 liters per minute)
Inlet - Outlet	1/4" quick connect fittings

This filter improves the taste and odor and reduces many chemical contaminants in drinking water.

This system has been tested according to NSF/ANSI 42 and 53 for the reduction of the substances listed below. The concentration of the indicated substances in water entering the system was reduced to a concentration less than or equal to the permissible limit for water leaving the system, as specified in NSF/ANSI 42 and 53. The testing was performed using spiked tap water at a flow rate of 0.5 GPM (1.9 L/min.), pH of 7.5 ±0.5, pressure of 60 PSIG, and temperature of 68 ±5°F.

**IMPORTANT NOTICE:** Read this performance data and compare the capabilities of this unit with your actual water treatment needs. It is recommended that, before purchasing a water treatment unit, you have your water supply tested to determine your actual water treatment needs. This filter system is designed to be used for the reduction of the performance claims listed below. Do not use where water is microbiologically unsafe or of unknown quality, without adequate disinfection before or after the system. Systems certified for cyst reduction may be used on disinfected water that may contain filterable cysts. While testing was performed under standard laboratory conditions, actual performance of the system may vary based on local water conditions. Some or all of the contaminants reduced by this unit may not be in your water supply. **See elsewhere in this manual for instructions on filter cartridge replacement, system installation, operating procedures, and warranty. The maintenance instructions must be followed for the product to perform as indicated below.**

**NOTE:** See labels on the water treatment system for additional information.

PERFORMANCE CLAIMS						
Contaminant	Required Influent Level (mg/L) <sup>②</sup>	NSF Max. Permissible Effl. Level (mg/L) <sup>②</sup>	Average Influent Level (mg/L) <sup>②</sup>	Avg. / Max. Effluent Level (mg/L) <sup>②</sup>	Avg. / Min. Percent Removal	EPA <sup>①</sup> Max. Contaminant Level (mg/L) <sup>②</sup>
Cyst	≥50,000 #/mL <sup>④⑤</sup>	99.95% <sup>③</sup>	150,000 #/mL <sup>④</sup>	<1 / <1 #/mL <sup>④</sup>	99.9 / 99.9	None <sup>⑥</sup>
Lead @ pH 6.5	0.15 ±10%	0.010	0.152	0.001 / 0.001	99.3 / 99.3	0.015
Lead @ pH 8.5	0.15 ±10%	0.010	0.150	0.001 / 0.001	99.3 / 99.3	0.015
Atrazine	0.009 ±10%	0.003	0.0092	0.0019 / 0.0022	87.3 / 76.8	0.003
Lindane	0.002 ±10%	0.0002	99.0	0.00002 / 0.00002	99.0 / 99.1	0.0002
Turbidity	11 ±1 NTU	0.5 NTU	11 ±1 NTU	0.2 / 0.4 NTU	98.5 / 96.4	None
<b>Substance</b>						
Chlorine Taste & Odor	2.0 ±10%	50% <sup>③</sup>	2.0	0.05 / 0.08	97.5 / 96.2	None <sup>⑥</sup>
Particulate Class I	10,000 mg/L	85%	9,000,000 particles/mL	14,000 / 14,000	99.9 / 99.8	None

① Environmental Protection Agency maximum contaminant level as required under the Safe Drinking Water Act.

② Milligrams per liter, which is equivalent to parts per million (PPM).

③ NSF minimum percent reduction requirement. Acceptance level for this substance is based on percent reduction, rather than maximum effluent concentration.

④ Particles per milliliter.

⑤ Microspheres was used as a surrogate.

⑥ The EPA has not determined a maximum contaminant level for this chemical.

---

# Before You Start

- ▼ Read all steps and guides carefully before installing and using your water filtration system. Follow all steps exactly to correctly install. Reading this manual will also help you to get all the benefits from the filtration system.
- ▼ Do not use with water that is microbiologically unsafe or of unknown quality without adequate disinfection before or after the system. This system is certified for cyst reduction and may be used on disinfected waters that may contain filterable cysts.
- ▼ All plumbing should be done in accordance with local codes and requirements. In Massachusetts, plumbing code 248 CMR 3.00 and 10.00 shall be adhered to. Consult with your licensed plumber.
- ▼ The water filtration system works on water pressures of 30 psi (minimum) to 100 psi (maximum). If your house water pressure is over the maximum, install a pressure reducing valve in the water supply pipe to the filtration system.
- ▼ Do not install the filtration system outside, or in extreme hot or cold temperatures. Temperature of the water supply to the filtration system must be between 40°F and 100°F. Do not install on hot water.

## Dimensions

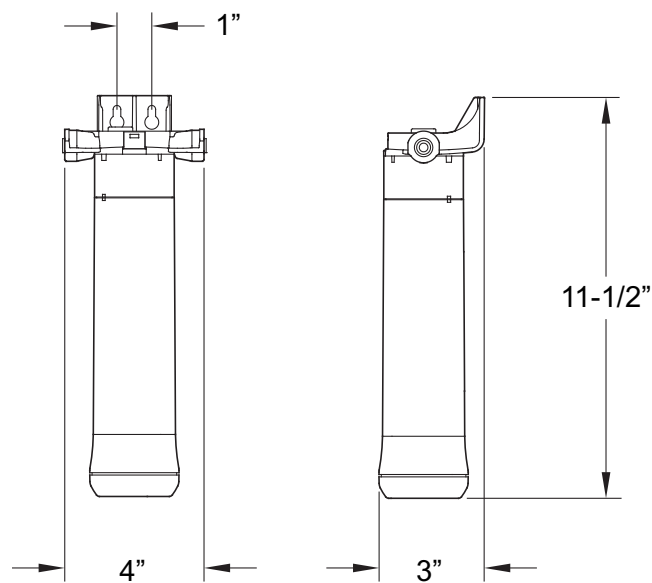

FIG. 1

**Questions? Call Toll Free 1-866-986-3223** Monday- Friday, 8 AM - 7 PM EST  
or visit [whirlpoolwatertreatment.com](http://whirlpoolwatertreatment.com)

When you call, please be prepared to provide the model number and date code, found on the filter head.

# Parts & Tools

## Included:

- Filter head, bracket & mounting screws
- Filter cartridge

## Not Included:

- Slotted and Phillips screwdrivers
- Pliers and adjustable jaw wrench
- Tubing cutter

## Pre-Installation Inspection

Thoroughly check the water filtration system for possible shipping damage and parts loss. Also inspect and note any damage to the shipping carton. Remove and discard (or recycle) all packing materials. To avoid loss of small parts, we suggest you keep the small parts in the parts bag until you are ready to use them.

## Installation Location

1. Close a water shutoff valve upstream from where you will install the filter, and activate the refrigerator water dispenser to relieve pressure in the cold water supply tubing.
2. Install the water filtration system in the cold water supply tubing, where accessible for filter changes. This could be behind the refrigerator, the cabinet under the sink, the basement, etc.

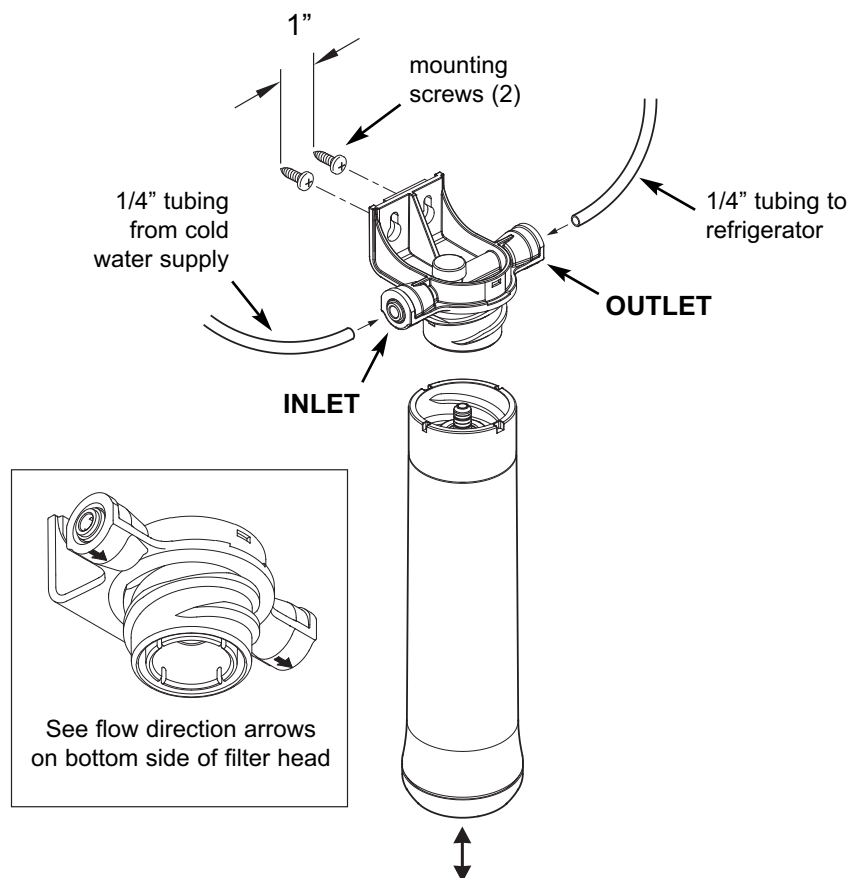

**NOTE:** Be sure to allow a minimum space of 1-1/2" under the system for removing the filter cartridge to change it.

**FIG. 2**

# Installation Instructions

## Make Tubing Connections

Your water filtration system includes push-in fittings for quick tubing connection. Review the following instructions before connecting the tubes. Failure to follow these instructions may lead to future leaks.

### Connect Tubing:

1. Use a tube cutter to cut the end of tubing square.
2. Inspect the end (about 1") of the tubing to be sure there are no nicks, scratches or other rough spots. If needed cut the tubing again.
3. Push tubing through the collet and all the way into fitting. Full engagement is 11/16" length of tube into the fitting.

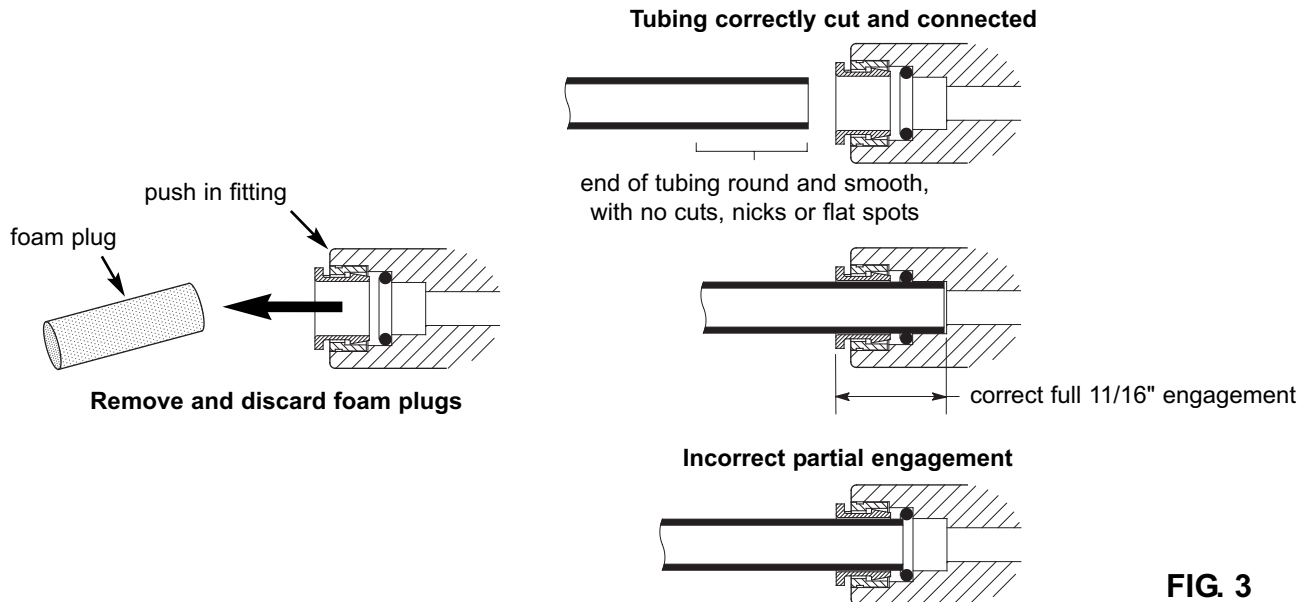

FIG. 3

### To Disconnect Tubing:

1. Push the collet inward and hold with a finger while pulling the tubing out.

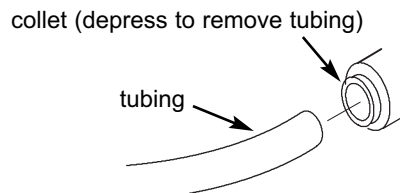

FIG. 4

## Turn On Water, Check for Leaks and Rinse Carbon Fines

1. Open any shutoff valve(s) that you closed at the beginning of this installation.
2. Activate the refrigerator water dispenser to purge air from the system. When the water runs smooth, with no bubbles or spurting, close faucet and check installation for leaks.
3. Let the water run for 10 minutes to rinse out carbon fines.

# Filter Cartridges

## Filter Cartridge Life

**Taste and Odor Cartridges:** A taste and odor cartridge contains activated carbon. When new, open the filtered water faucet and allow fine, carbon particles to purge from the cartridge. Flush for 10 minutes. It is recommended to **replace filter cartridge every six months** of use. There are several variables that determine how long a cartridge will last. These include:

1. How much water you use, and
2. How much sediment, taste and/or odor, or other unwanted substance, is in the water.

Use the following information as a guide. However, no matter which type of cartridge you are using, you will know it is time to replace them when you first notice the return of the unwanted sediment, taste and/or odor in your water, or when the flow diminishes or stops.

Whirlpool® In-Line Refrigerator Water Filtration System model WHARSS5 with replacement element WHARSF5 conforms to NSF/ANSI 42 and 53 for the specific performance claims as verified and substantiated by test data. The rated capacity for this system is 750 gallons (2840 liters) at a rated service flow of 0.5 gallons per minute (1.89 liters per minute).

Cartridges should be replaced every 750 gallons or six months, whichever comes first. For replacement elements, call 1-866-986-3223 or contact your nearest Lowes store. Replacement filter prices will vary. Current pricing for replacement filters is approximately \$20.00 to \$40.00 per filter element.

## Filter Cartridge Replacement

**NOTE:** There is no need to shut off the water supply when replacing the filter cartridge.

1. Turn filter cartridge to the left to remove cartridge from the filter head.
2. Dispose of the cartridge in a proper manner.
3. Install new cartridge. Turn cartridge to the right to re-attach to the filter head.

**Taste and Odor Cartridges:** Taste and odor cartridges contain activated carbon, a black powder. When new, open the filtered water faucet and allow fine, carbon particles to purge from the cartridge. Flush for 10 minutes.

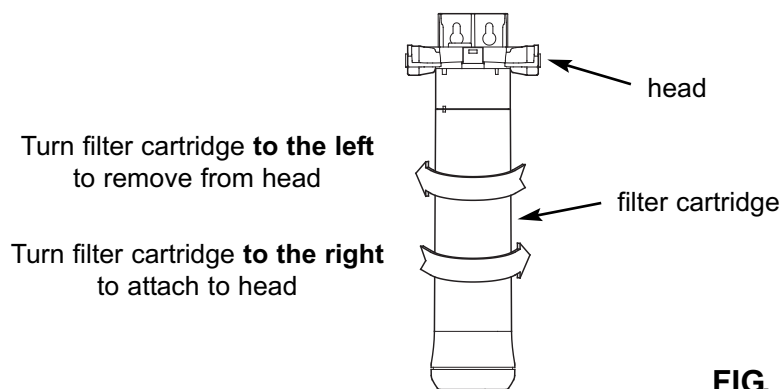

**Register for reminders to change filters  
at [whirlpoolwatertreatment.com](http://whirlpoolwatertreatment.com)**

**Questions? Call Toll Free 1-866-986-3223** Monday- Friday, 8 AM - 7 PM EST  
or visit [whirlpoolwatertreatment.com](http://whirlpoolwatertreatment.com)

When you call, please be prepared to provide the model number and date code, found on the filter head.

# Troubleshooting the System

<b>Problem: Taste and/or Odor.</b>	
<b>Cause:</b> Filter cartridge exhausted.	<b>Correction:</b> Replace filter cartridge.
<b>Cause:</b> System contaminated.	<b>Correction:</b> Sanitize system. Call 1-866-986-3223 for instructions.
<b>Problem: Water leaks at push connect fittings.</b>	
<b>Cause:</b> Tubing not pushed in all the way.	<b>Correction:</b> Push tubing in all the way into fittings.
<b>Cause:</b> Tubing not cut square.	<b>Correction:</b> Cut tubing square.
<b>Cause:</b> Tubing nicked.	<b>Correction:</b> Remove nicked portion, reinsert tubing into fitting.
<b>Cause:</b> Outer tubing surface not smooth.	<b>Correction:</b> Remove rough portion, reinsert tubing into fitting.

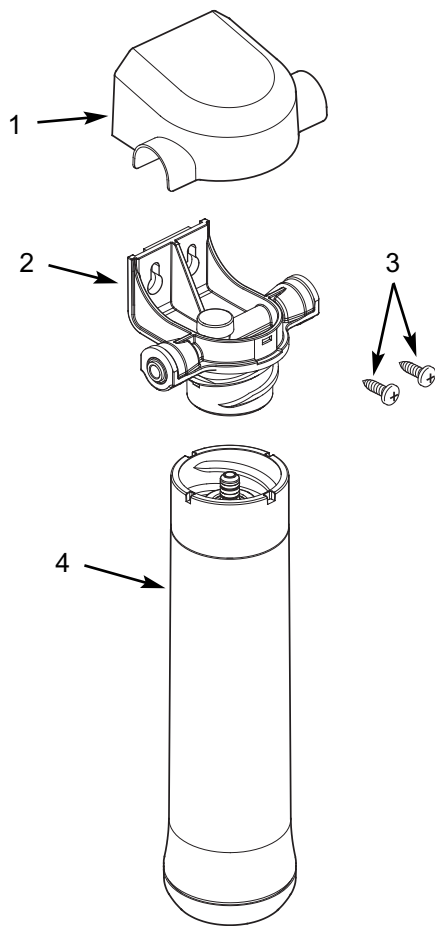

## Parts List

Key No.	Part No.	Description
1	1128-04-01	Cover
2	1128-04-HA	Head Assembly with Quick Connect Fittings
3	1073-26-AB	Mounting Screw (2 req.)
4	WHARSF5	Repl. Filter Cartridge, Taste & Odor *
■	201-8402812	Owner's Manual

\* Please purchase replacement cartridges from the retailer where you bought your water filtration system.

■ Not illustrated.

To order repair parts call toll free 1-866-986-3223,  
Monday - Friday, 8 am - 7 pm EST.

Manufactured and warranted by  
Ecodyne Water Systems  
1890 Woodlane Drive  
Woodbury, MN 55125



### FOR IOWA USE ONLY

All sales in Iowa require the following signature before consummation of sale. These signatures must be retained by seller/renter for 2 years minimum.

Buyer/Renter \_\_\_\_\_ Date \_\_\_\_\_

Seller \_\_\_\_\_ Date \_\_\_\_\_

Seller's Address \_\_\_\_\_

Seller's Phone No. \_\_\_\_\_

**Product: Whirlpool® In-Line Refrigerator Water Filtration System - Model WHARSS5**